



2M

Thin Film Based Thermopile Detector

Features: A thin film-based single element thermopile detector that offers the world's highest sensitivity in a TO-5 package. Dare to compare. Low noise voltage of $12.8\text{nV}/\sqrt{\text{Hz}}$.

Options: 1) See [Standard Windows and Filters](#) for list of optical filter options. 2) Internal $30\text{k}\Omega$ 5% NTC chip thermistor provides ambient package temperature measurement. Resistance Weld package only. See [Thermistor Options](#) p/n: DC-4005. 3) Order this unit encapsulated with Xenon and this becomes a super-high output detector with very low noise. See [Thermopile Configuration Table](#) for more options.

Applications: Excellent for gas analysis, fire detection and non-contact temperature measurement.

Benefit: Extremely high output with best signal-to-noise performance with a time constant of 85ms when encapsulated with Argon gas.

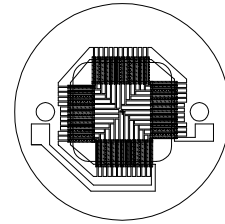

Detector circuit overlay



2M

Technical Specifications

Specifications apply at 23°C with KBr Window and Argon encapsulating gas

Parameter	Min	Typical	Max	Symbol	Units	Comments
Active Area size		2 x 2		AA	mm	Hot junction size, per element.
Element Area		4		A	mm ²	
Number of Junctions		48				Per element.
Number of Channels		1				Per detector package.
Output Voltage	200	250	300	V _s	μV	DC, H=330μW/cm ² (3)
Signal-to-Noise Ratio	12,739	19,531	33,333	SNR	√Hz	DC, SNR=V _s /V _n
Responsivity	15.2	18.9	22.7	ℜ	V/W	DC, ℜ=V _s /HA (2)
Resistance	5	10	15	R	kΩ	Detector element
Temperature Coefficient of ℜ		-36			%/°C	Best linear fit, 0° to 85°C (1)
Temperature Coefficient of R		-2			%/°C	Best fit, 0° to 85°C (1)
Noise Voltage	9.0	12.8	15.7	V _n	nV/√Hz	V _n ² =4kTR
Noise Equivalent Power	.40	.68	1.03	NEP	nW/√Hz	DC, NEP= V _n HA/V _s (2)
Detectivity	1.9	3.0	5.0	D*	10 ⁸ cm√Hz/W	DC, D*=V _s /V _n H√A (2)
Time Constant		85		τ	ms	Chopped, -3dB point (1)
Field of View		38°/95°		FOV	Degrees	See Assembly Drawings for FOV Description.
Package Type		TO-5				Standard package hole size: Ø.150"
Operating Temperature	-50		100	T _a	°C	

General Specifications: Flat spectral response from 100nm to > 100μm. Linear signal output from 10⁻⁶ to 0.1W/cm². Maximum incident radiance 0.1W/cm², damage threshold ≥ .5W/cm²

Notes: (1) Parameter is not 100% tested. 90% of all units meet these specifications. (2) A is detector area in cm². (3) Test Conditions: 500K Blackbody source; Detector active surface 10cm from 0.6513cm Diameter Blackbody Aperture.

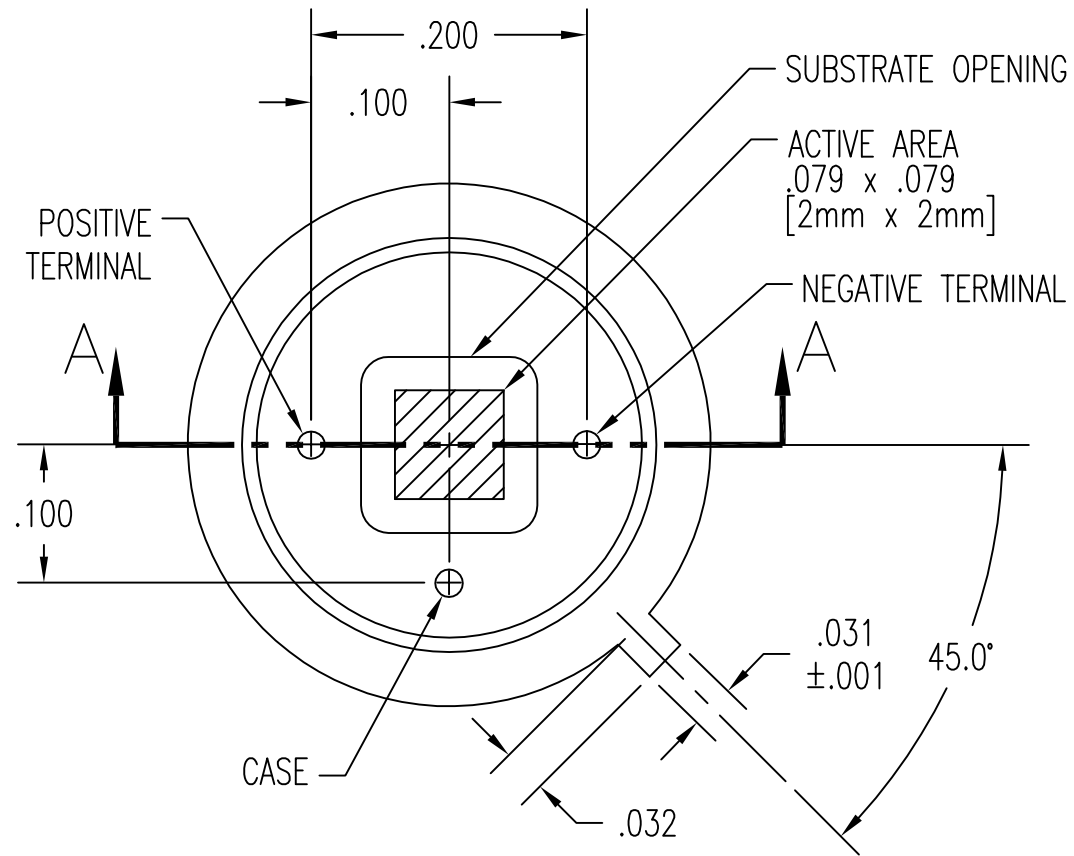

TOP VIEW
WITHOUT COVER

UNLESS OTHERWISE SPECIFIED, ALL DIMENSIONS ARE IN INCHES.		DEXTER RESEARCH CENTER, Inc.			
TOLERANCES ARE:		7300 Huron River Dr., Dexter, MI 48130, ph. 734-426-3921 fax 734-426-5090			
FRACTIONS	DECIMALS	ANGLES	ASSEMBLY, 2M, 2MC Au, 2MC Sb,		
±	.XX ±	±	w/ HEAT SINK, TOP VIEW		
	.XXX ± .005		SIZE:	SCALE:	DWG. NO.
APPROVALS	DATE		A	7" = 1"	1011.1
DRAWN:	DLJ	9/25/00	DRC PART NO.	MATERIAL:	REV. PAGE:
CHECKED:					A 1 OF 2
ENGINEERED:					FINISH:
APPROVED:					

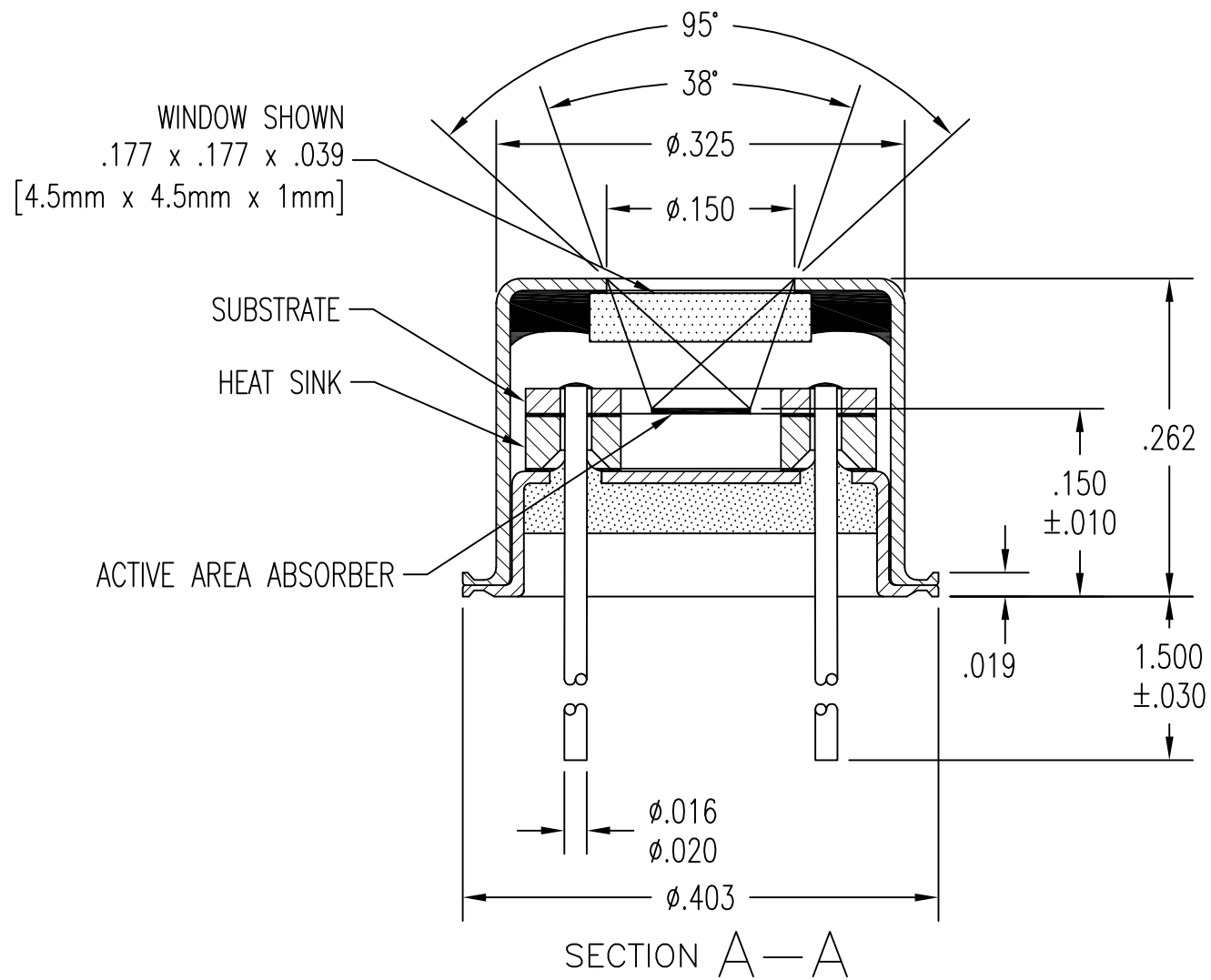

UNLESS OTHERWISE SPECIFIED, ALL DIMENSIONS ARE IN INCHES. TOLERANCES ARE:		DEXTER RESEARCH CENTER, Inc. 7300 Huron River Dr., Dexter, MI 48130, ph. 734-426-3921 fax 734-426-5090			
FRACTIONS ±	DECIMALS .XX ± .XXX ± .005	ANGLES ±	ASSEMBLY, 2M, 2MC Au, 2MC Sb, w/ HEAT SINK, CROSS SECTION		
APPROVALS	DATE	SIZE:	SCALE:	DWG. NO.	REV. PAGE:
DRAWN: DLJ	12/15/10	A	7" = 1"	1011.2	B 2 OF 2
CHECKED:		DRC PART NO.		MATERIAL:	FINISH:
ENGINEERED:					
APPROVED:					